

50108 & 50120 SHOREMASTER CANTILEVER LIFT

- OWNER AND OPERATORS MANUAL - Model 50108 & 50120

50108 Maximum load 5000 pounds - Inside lift width 108" (9FT)
50120 Maximum load 5000 pounds - Inside lift width 120" (10FT)

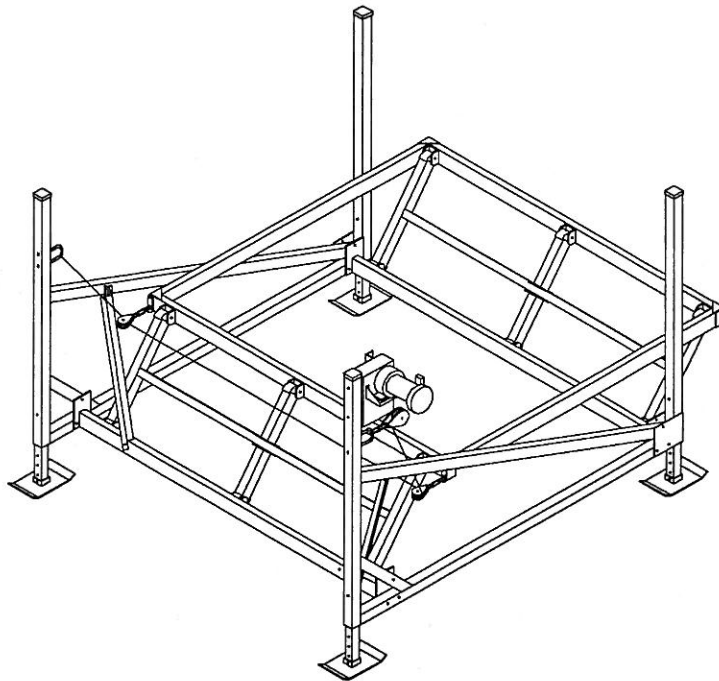

50108 & 50120 Cantilever

Manufactured by ShoreMaster Inc.
Revision No. (1) 1-8-97
ShoreMaster Inc.
1 ShoreMaster Drive - PO Box 358
Fergus Falls, MN 56538-0358
1-800-328-8945

MODEL 50108/50120

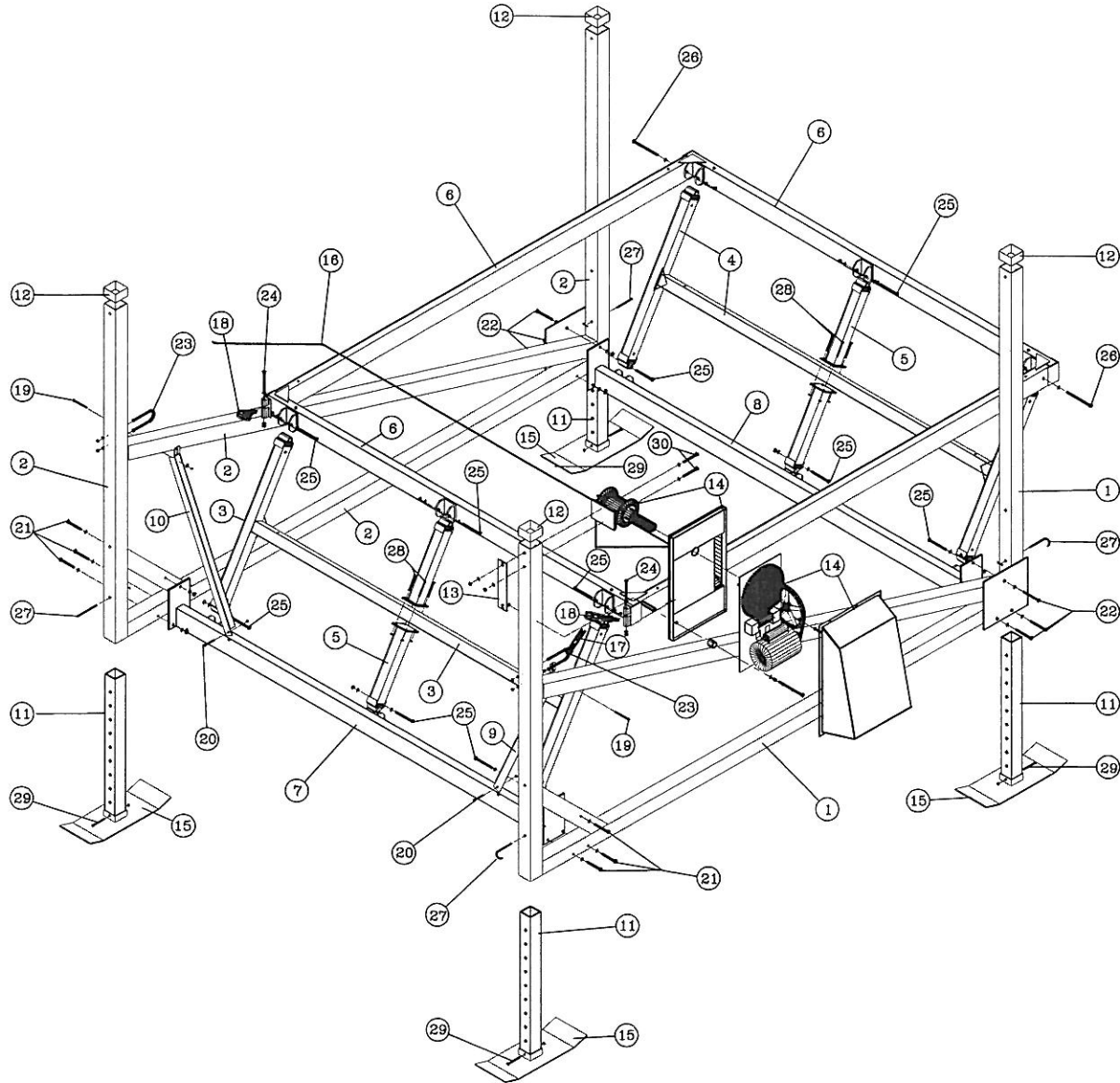

No.	DESCRIPTION
1	LEFT LIFT SIDE - 142.88", (1)
2	RIGHT LIFT SIDE - 142.88", (1)
3	FRONT I-BEAM - 94.13", (1)
4	REAR I-BEAM - 100.88", (1)
5	I-BEAM MIDDLE LEG - 19", (4)
6	TOP CRADLE RACK - 106"W x 124"L, (1)
7	FRONT BOTTOM BEAM - 108", (1)
8	REAR BOTTOM BEAM - 108", (1)
9	LARGE LIFT BRACE LEFT - 41", (1)
10	LARGE LIFT BRACE RIGHT - 41", (1)
11	I-3 LEG POST - 36", (4)
12	#9 BLUE CAP, (4)
13	WINCH PLATE - 12", (1)
14	ELECTRIC POWER UNIT, (1)
15	I-3 LIFT PAD, (4)
16	5/16" x 23.5' SS CABLE, (1)
17	STEEL PULLEY SMALL COMPLETE W/2 LINK CHAIN, (1)
18	STEEL PULLEY LARGE COMPLETE W/3-LINK CHAIN, (2)
19	(1) 3/8" x 4-1/2" MACHINE BOLT, (1) 3/8" WASHERS, (1) 3/8" NUT, (2 PLACES)
20	(1) 3/8" x 3" MACHINE BOLT, (1) 3/8" NUT, (2 PLACES)
21	(1) 1/2" x 5" GRADE 5 MACHINE BOLT, (2) 1/2" WASHERS, (1) 1/2" NUT, (6 PLACES)
22	(1) 1/2" x 5" GRADE 5 MACHINE BOLT, (2) 1/2" WASHERS, (1) 1/2" NUT, (6 PLACES)
23	(1) 1/2" x 5-1/8" U-BOLT, (2) 1/2" WASHERS, (2) 1/2" NUTS, (2 PLACES)
24	(1) 1/2" x 5" GRADE 5 MACHINE BOLT, (1) 1/2" NUT, (2 PLACES)
25	(1) 1/2" x 5" GRADE 5 MACHINE BOLT, (2) 1/2" WASHERS, (1) NYLOCK NUT, (10 PLACES)
26	(1) 1/2" x 7" GRADE 5 MACHINE BOLT, (2) 1/2" WASHERS, (1) NYLOCK NUT, (2 PLACES)
27	(1) 3/8" x 3-29/32" PIN, (1) PIN CLIP, (4 PLACES)
28	(1) 3/8" x 4" MACHINE BOLT, (1) 3/8" NUT, (8 PLACES)
29	(1) 1/2" x 4" MACHINE BOLT, (1) 1/2" NUT, (4 PLACES)
30	(1) 1/2" x 4-1/2" or 5" MACHINE BOLT, (2) 1/2" WASHERS, (1) 1/2" NUT, (2 PLACES)

TABLE OF CONTENTS

<u>PAGE</u>	<u>SECTION</u>
3	Introduction
3	Warnings and Safety
4-5	Parts List 50108 & 50120
6-14	Assembly 50108 & 50120 Lift
15-16	Installation
17-19	Operation -Loading, Raising, Lowering
20	Removal and Storage
21	Service

INTRODUCTION

A ShoreMaster 50108 & 50120 cantilever lift will lift your boat up and out of the water for dockside storage. The 50108 & 50120 is designed to rest on a stable lake bottom. This lift works best in non-fluctuating water with depths of over 3 feet. There are maximum allowable water depths for the lift depending on leg lengths and location. A properly positioned lift provides safe, convenient, quick mooring for your craft.

The lift functions by turning the lift hand wheel clockwise to raise the lift. Properly position your boat in the lift and it will raise with the lift rack. The wheel is turned counterclockwise to lower the lift.

Information in this manual is not all inclusive and cannot cover all unique situations. If you have questions about assembly, installation, operation or suitability of this product contact an authorized ShoreMaster dealer or ShoreMaster toll-free **1-800-328-8945**.

WARNINGS AND SAFETY

Your **SAFETY** is the most important issue related to this product. It is critical that all assemblers, installers and users read and fully understand the warnings and safety information contained throughout this manual before using this product.

Safety Instructions

Never exceed recommended weight capacity of your lift. The weight of your boat includes the hull, engine, fuel, gear, battery, and added accessories. The dry weight reported by the manufacturer usually includes only basic boat and engine. The manufacturers reported weights can be understated by 10 -30%! This is before you add fuel, fluids, batteries, accessories, etc.! Weigh your boat at a certified scale to be absolutely sure of the total weight. You will be lifting 20 - 50% more than the reported dry weight when everything is considered.

- ✂ A properly educated or trained person is needed for assembly and installation of this product. Call ShoreMaster if you have questions.
 - ✂ Wear proper protective clothing and eye wear when assembling or installing lift.
 - ✂ Do not assemble, install or use this product if items are missing or damaged.
 - ✂ **If fast spin down of wheel occurs do not touch wheel or attempt to stop. Allow your boat to splash into water, it should not damage your boat! Placing hands or feet on spinning wheel can cause broken or cut limbs.**
- ✂ **WARNING - Stay clear of lift (facing wheel) while operating. Do not allow anyone on, in or under lift. A cable or lift part failure can cause a sudden drop of boat, resulting in a crushing or falling injury or death!**
- ✂ Do not allow people on boat when it is on lift in raised position.
 - ✂ Do not make alterations or adjustments to lift or accessories when boat is on lift.
 - ✂ Check cables for frays, corrosion or breaks at least once a month. A cable breaking while boat is in lift could damage boat or lift. Severe bodily injury could also occur.

50108 & 50120 LIFT PARTS LIST

Before assembly, identify each part. Remove parts from boxes, bags and bundles. Mark each item with the proper part letter (indicated in the left-hand column). This will confirm that all parts are here before beginning assembly and allows you to easily follow the assembly instructions.

****DO NOT CONFUSE SHOREMASTER I.D. STICKERS ALREADY PLACED ON PARTS. THESE LETTERS OR NUMBERS ARE FOR PACKING LIST IDENTIFICATION AND MAY NOT CONFORM TO I.D. LETTERS OR NUMBERS USED IN THIS INSTRUCTION MANUAL.**

50108 & 50120 Winch Box & Bolt Bag:

<u>Part ID</u>	<u>Qty.</u>	<u>Description</u>
AA	3	Pulley with 3 Link Chain
BB	1	Cable (1/4" x 22' - 6" 50108) (1/4" x 23' - 6" 50120)
CC	1	SM Winch (5000 series)
DD	4	#9 Blue Caps
EE	1	Wheel to Winch Bolt Kit
FF	1	Cable Guide
GG	1	ShoreMaster Winch Plate

Tools Needed For Assembly

2 - 9/16" Combo Wrench
1 - 7/16" Combo Wrench
1 - 3/16" Allen Wrench
2 - 6' Pieces of Strong Nylon Rope

Bolt Bag:

2 - 3/8" x 3" Hex Bolts
8 - 3/8" x 4" Hex Bolts
2 - 3/8" x 4 1/2" Hex Bolts
4 - 1/2" x 4" Hex Bolts
2 - 1/2" x 4 1/2" Hex Bolts
24 - 1/2" x 5" Hex Bolts
2 - 1/2" x 7" Hex Bolts
2 - 1/2" x 5 1/8" U-Bolts
4 - 3/8" x 3 29/32" Pins
4 - Pin Clips
12 - 3/8" Nuts
12 - 1/2" Locking Nuts
24 - 1/2" Hex nuts
2 - 3/8" Washers
56 - 1/2" Washers

PART A
LEFT LIFT SIDE
QTY. 1

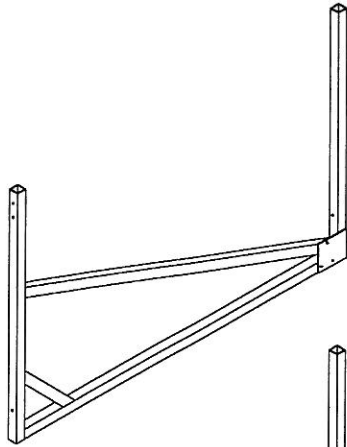

PART B
RIGHT LIFT SIDE
QTY. 1

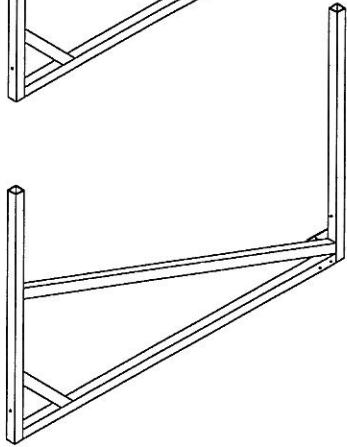

PART C
LEG PAD
QTY. 4



PART D
LEG POST
QTY. 4



PART E
FRONT BOTTOM BEAM
QTY. 1

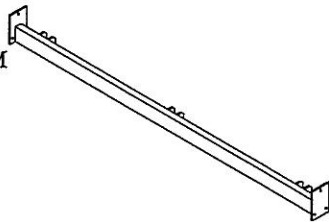

PART F
REAR BOTTOM BEAM
QTY. 1

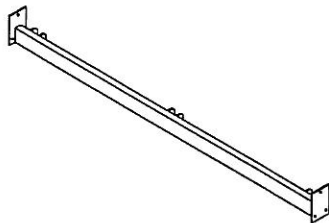

PART G
FRONT I-BEAM
QTY. 1

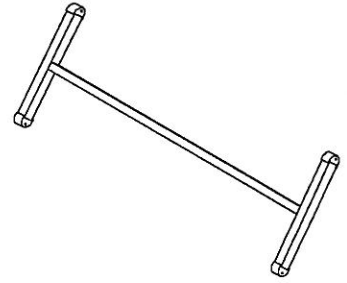

PART H
REAR I-BEAM
QTY. 1

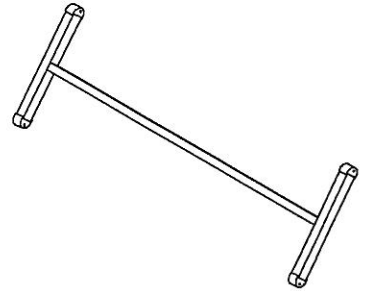

PART I
LEFT SIDE BRACE
QTY. 1



PART J
RIGHT SIDE BRACE
QTY. 1



PART K
MIDDLE LEG
QTY. 2 PAIR



PART L
TOP RACK
QTY. 1

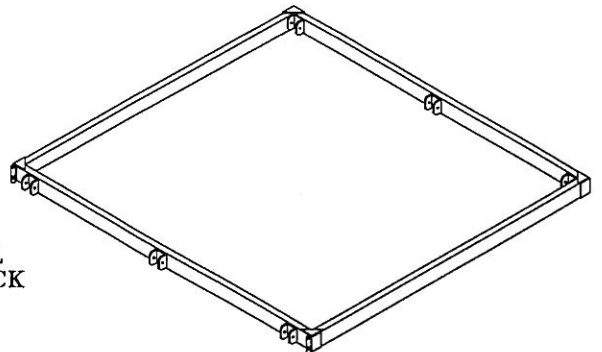

ASSEMBLY OF 50108 & 50120 LIFT

****Fully read and understand each step before proceeding with that step.**

****Only hand tighten bolts and nuts until lift is completely assembled.**

#1 Slide DD parts (blue caps) on uprights as shown.

#2 Insert D part (leg post) into C part (foot pads) and secure using (4) $\frac{1}{2}$ " x 4" Hex bolts and (4) $\frac{1}{2}$ " nuts. Insert D parts (legs) into part A and part B (left & right lift sides) as shown. Use one $\frac{3}{8}$ " x 3 $\frac{29}{32}$ " pin with pin clip for each leg.

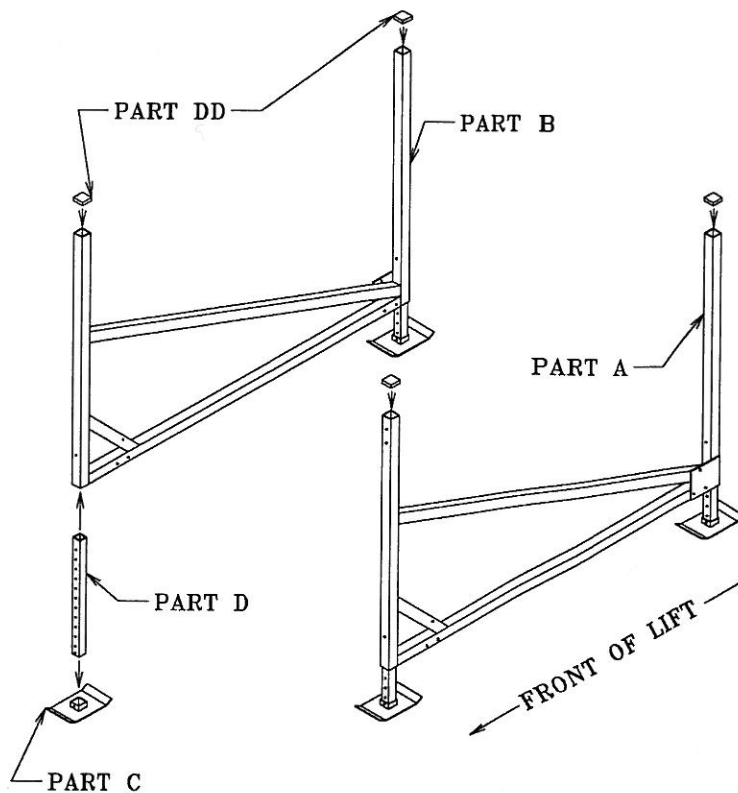

#3 Place A part (left side) and B part (right side) about nine or ten feet apart as shown. Attach part E (front bottom beam) to A & B parts as shown. Use (3) ½" x 5" hex bolts, (6) ½" washers and (3) ½" nuts at each end.

Note: The square plate welded to the lift sides must face outward to properly attach bottom beams.

Note: The front bottom beam has hinges welded closer together. The rear bottom beam has hinges welded farther apart.

#3B Attach part F (rear bottom beam) to A & B parts as shown. Use (3) ½" x 5" hex bolts, (3) ½" nuts and (6) ½" washers at each end.

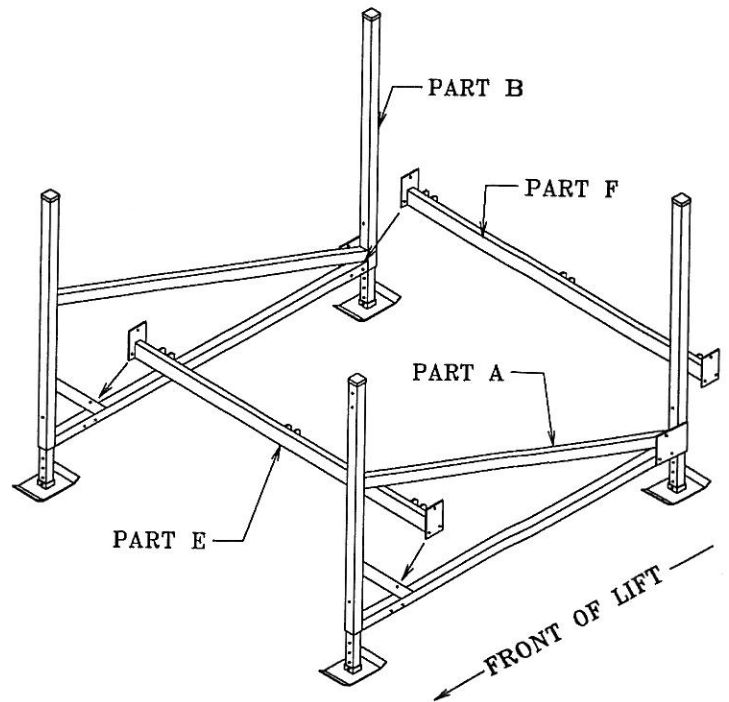

#4 Attach G part (Front I-beam) to part E, attach H part (rear I-beam) to Part F as shown. Use (2) ½" x 5" Hex Bolts, (2) ½" locknuts & (4) ½" washers per G & H parts.

Note: Do not over tighten lock nuts. This connection must move freely during operation.

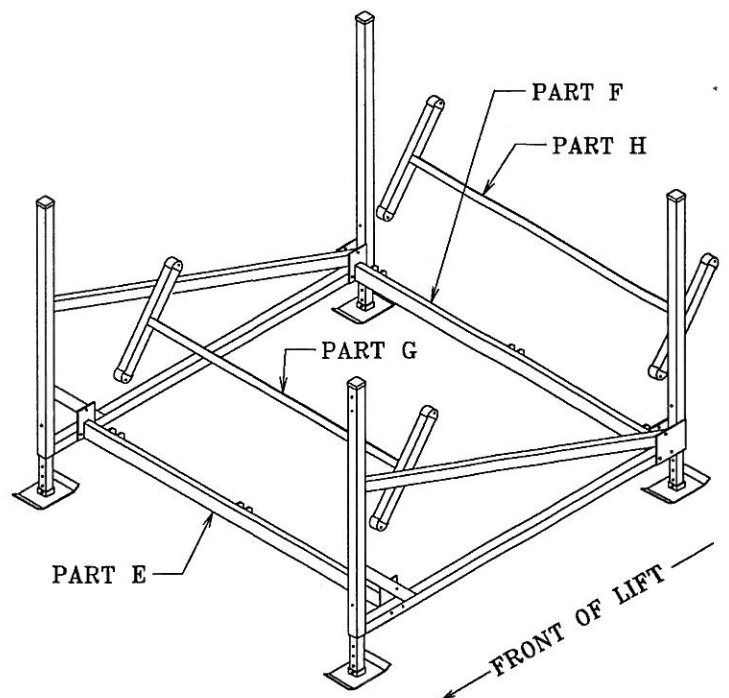

#5 Attach part I (left side brace) & part J (right side brace) to part E (front bottom beam) and to parts A & B (sides) as shown. Use (2) 3/8" x 4 1/2" hex bolts, (2) 3/8" nuts and (2) 3/8" washers to attach to the lift sides, use (2) 3/8" x 3" hex bolts, (2) 3/8" nuts to attach to bottom beams. Bolts should face thread side out.

Note: The washers are used on forked end of brace. Forked ends attach to sides. Place between bolt head and brace.

Note: If lifting a wide pontoon, float boat or deck boat you often cannot use standard braces. They could interfere with your boat fitting in the lift properly.

Note: Lift sides should be at a 90-degree angle to your bottom beam after attaching braces.

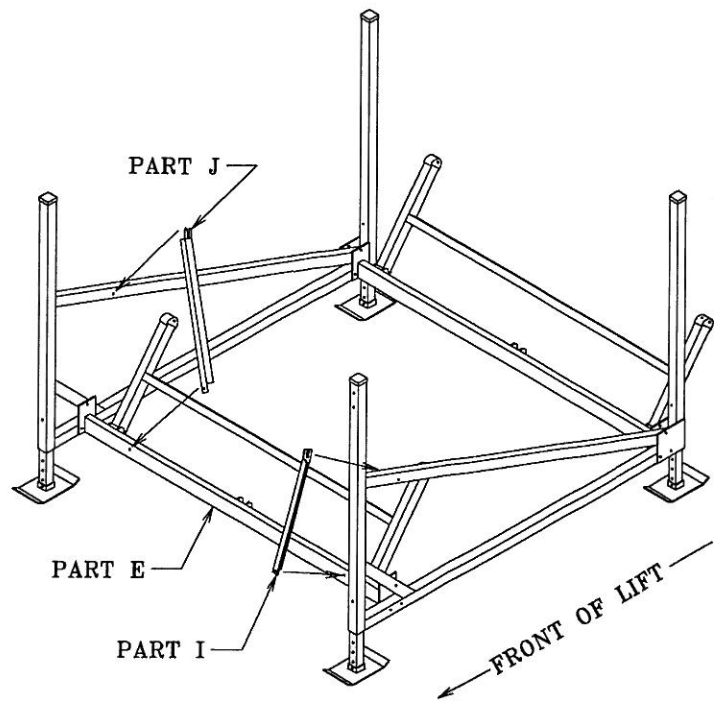

CAUTION

Bolts securing braces to lift sides should be placed so threaded side faces out. This prevents cable from catching under bolt threads should you allow slack in cable during use. Not doing this could result in cable fraying from rubbing on bolt threads.

#6 Attach K parts (middle legs) to parts E & G (front bottom beam and I-beam) and to parts F & H (rear bottom beam and I-beams) as shown. Use (4) 3/8" x 4" hex bolts and (4) 3/8" nuts for attaching each pair together around G & H parts. Then attach to bottom beams using (2) 1/2" x 5" hex bolts, (2) 1/2" lock nuts and (4) 1/2" washers.

Note: Do not over tighten lock nuts. This connection must move freely during operation.

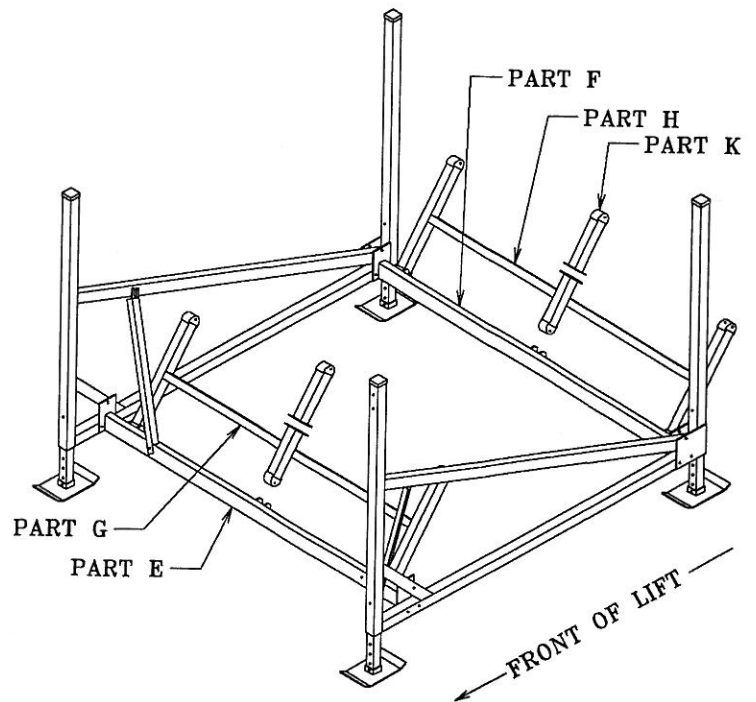

#7 Attach part L (top rack) to parts G, H & K as shown. Use (4) ½" x 5" hex bolts, (4) ½" locknuts and (8) ½" washers and (2) ½" x 7" hex bolts with ½" locknuts and (4) ½" washers. The ½" x 7" hex bolts go in the corners in back of lift.

Note: Be sure part L is attached exactly as shown. Do not attach upside down or backwards.

Note: Do not over tighten lock nuts. This connection must move freely during operation.

Note: You may want to shorten G & H parts if you are in permanently shallow water and have a boat that does not draft much water and your craft weighs close to your lift capacity.

*** This is accomplished by cutting 8" off top of G & H parts, about 1" above hole already drilled in G & H parts. This will make your lift easier to operate. However, you only have 32" of lift height instead of 40" normally provided.

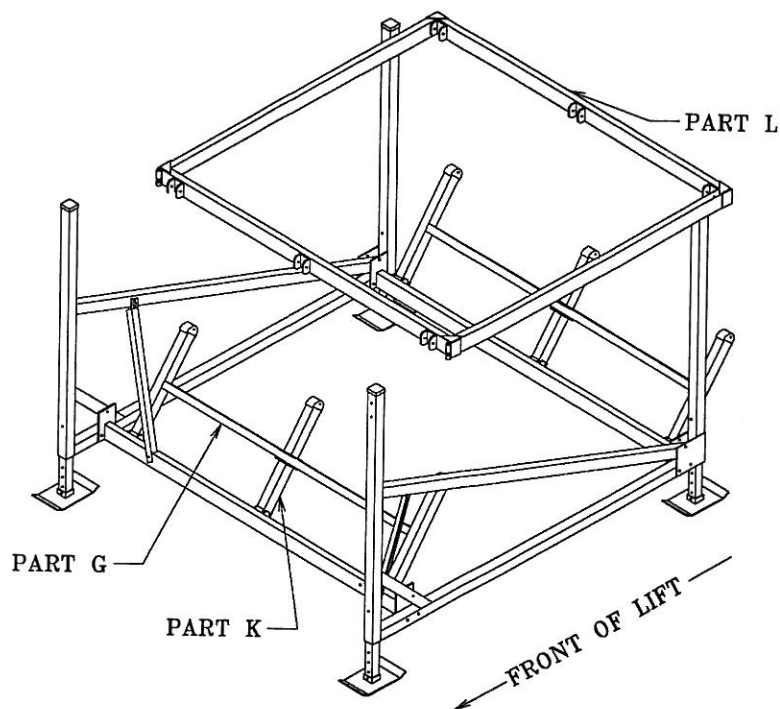

#8 Determine where you will position your lift alongside your dock. The side facing your dock is where the winch and wheel attachment will be mounted.

#9 Tie ropes from part L (lift rack) to parts A or B (side upright) in opposite corners. This prevents rack from pivoting during remaining assembly and during installation.

CAUTION

A freely pivoting lift rack could cause a pinching or cutting injury during installation. Be sure lift rack is properly secured when installing. Never move or lift your boat lift by grabbing the lift rack or I-beams.

#10 Attach AA part (pulley with three link chain) to part A or part B, as determined in step #8. Use (1) ½" x 5 1/8" U-bolt with (2) ½" washers and (2) ½" nuts to attach.

Note: The AA part must be attached to the proper side. Attach pulley to the side you will be mounting your winch on.

Note: The washers are placed next to nut when attaching.

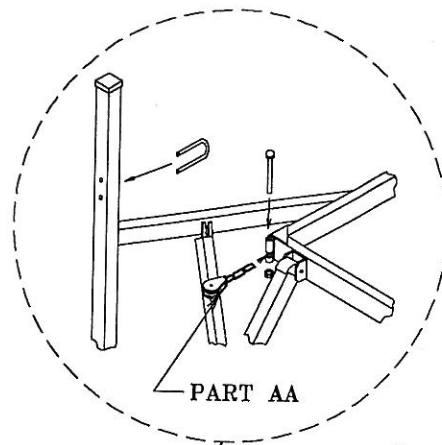

#11 Attach two AA parts (pulleys with three link chain) to Part L (top rack) as shown. Use (1) ½" x 5" hex bolt and (1) ½" nuts to attach each pulley.

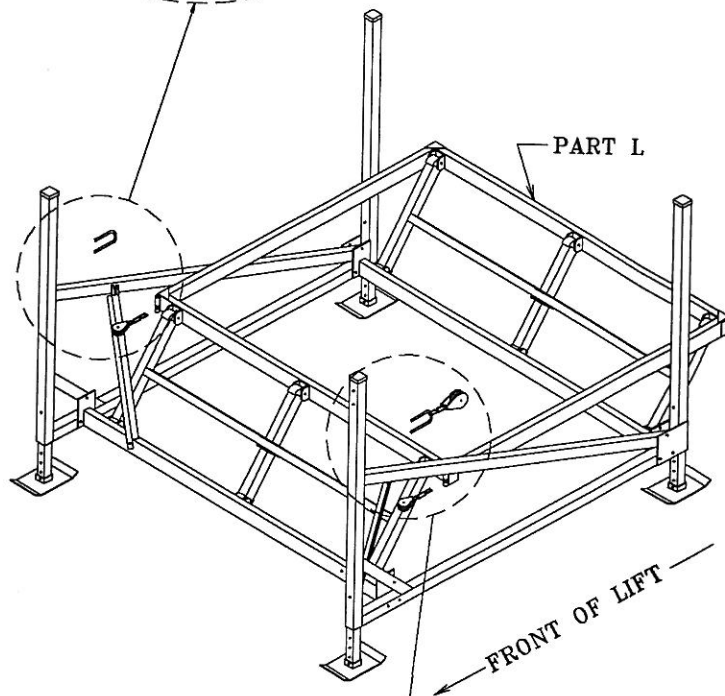

#12 Slide end of cable with cable clamps through the ½" x 5 1/8" U-bolt and attach to the opposite lift side with (2) ½" washers and (2) ½" nuts.

Note: This U-bolt must be attached to the proper side. Attach it to the side you will **not** be mounting your winch on.

Note: The washers are placed next to nut when attaching.

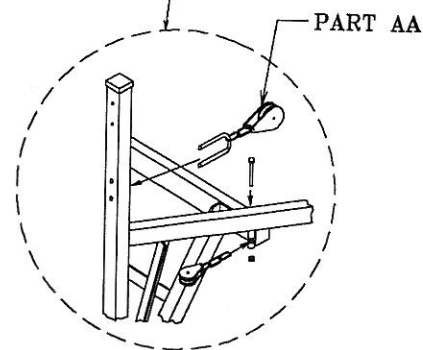

#13 Thread BB part through all three pulleys as shown.

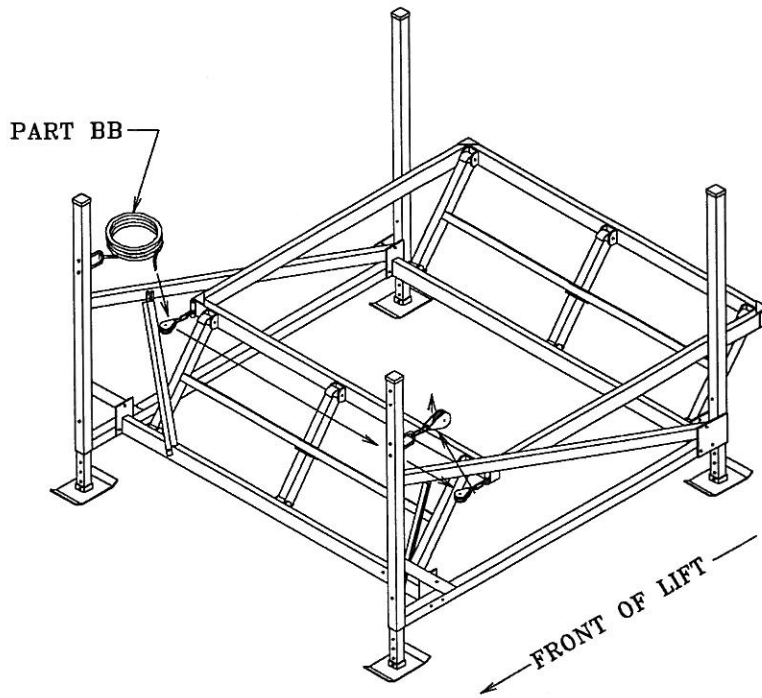

#14 Attach BB part to CC part (winch) as shown.

Slide cable end into slotted opening in winch hub.
Tighten winch hub set screw to secure cable to winch hub.

Note: Cable must enter at slotted end of opening through hub as shown.

Note: Slide cable fully into hub opening. However, do not go so far that it sticks out other side of hole. This would interfere with proper cable wrapping.

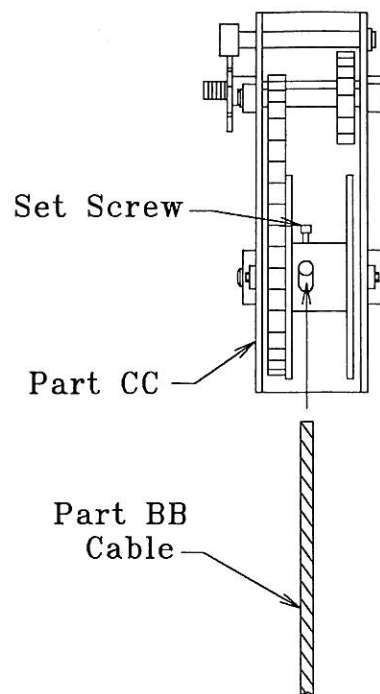

#15 Attach FF part (cable guide) to bottom of winch housing. Use the bolts and nuts that come attached to the cable guide. This guide prevents stacking of cable on winch hub.

Note: Cable guide and cable must be positioned properly so cable is between rollers on cable guide.

Note: Cable guide must be installed properly. The end of the cable guide with the rollers must be attached to the side of the winch that the cable is winding up on the winch hub. **NOT DOING SO WILL VOID YOUR WARRANTY!!!**

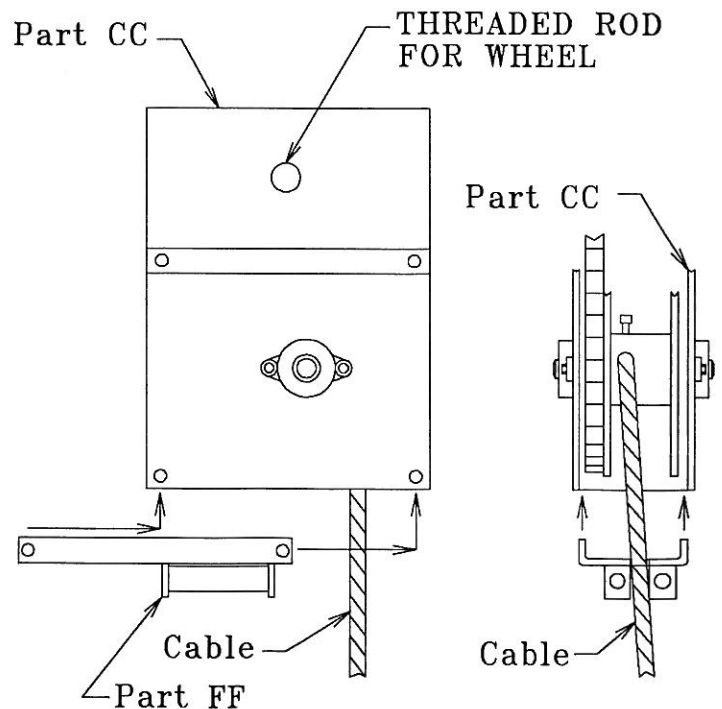

#16 Attach CC part (winch) to upright above AA part (pulley with three link chain) as shown. Use (2) ½" x 4 ½" hex bolts, (4) ½" washers, (2) ½" nuts & (1) ShoreMaster winch plate (part GG).

Note: You must remove winch cover to attach winch. Reattach cover when finished.

Note: Use two washers on each bolt. One against bolt head and one against nut.

<h2>CAUTION</h2>
Be sure winch and winch hub are attached exactly vertical when tightening bolts and nuts. Attaching crooked could result in premature cable wear.

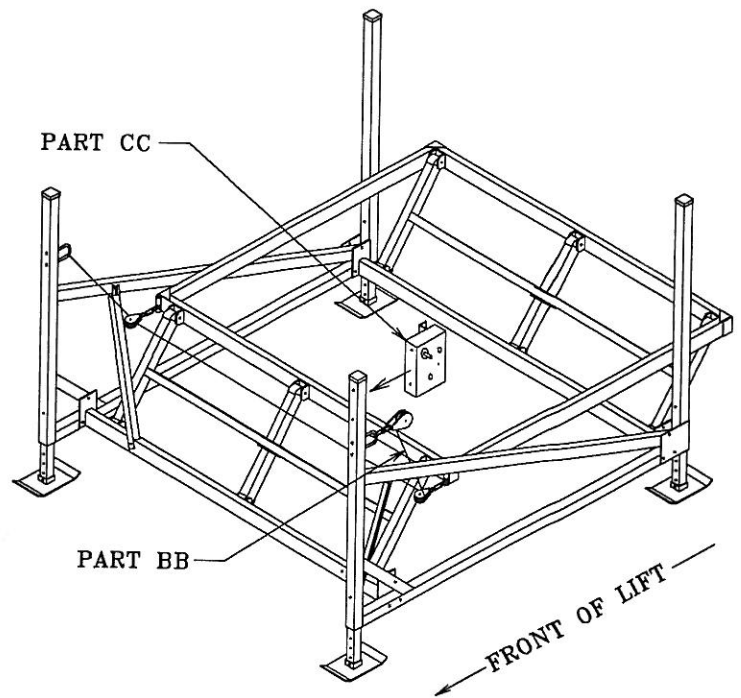

#17 Refer to page #22 for EPU instructions. After EPU is installed please refer back to Step 18 for winch cable installation, and final assembly instructions.

#18 Thread excess cable onto winch hub by turning winch driveshaft clockwise at this time. Applying tension to cable, by holding it tight when raising wheel, will help to develop proper wrap.

CAUTION

Be sure cable wraps tight and uniformly on hub.
Do not allow cable to wind up loosely on hub. Cables wrapping incorrectly will result in rapid cable wear.

CAUTION

Use a leather glove or other hand protection to avoid cuts when applying cable pressure.

#19 Firmly secure bolts and nuts at this time. Do not over tighten lock nut connections.

#20 Many accessories are available for use with this boat lift. See assembly instructions for each required accessory. Follow relevant safety instructions mentioned in this manual when attaching accessories.

50108 & 50120 Worm Drive Winch Instructions & Safety Tips

STEP 1

Using (2) ½" x 5" hex bolts, (4) ½" washers, (1) winch plate (#24) and (2) ½" nuts, bolt the winch hub (3) to the lift side that has the extended upright. Make sure the winch hub is square with the upright. This is the **only** place where the winch hub can be attached to the lift.

NOTE Make sure the winch hub shaft is extending toward the **outside** of the lift.

STEP 2

Slide back cover (7) over winch hub shaft. Slide spacer sleeve (4) onto winch hub shaft. Slide the plate(2) that has the worm drive unit on it onto the spacer sleeve and bolt in place using (1) ½" x 3 ½" machine bolt, (1) center lock nut (*this will be a nut with dents in the side*). When securing the bottom of the plate to the upright, use an aluminum spacer (15) between the plate and the lift upright, using (1) 3/8" x 7 ½" machine bolt, (2) 3/8" washers & (1) 3/8" nut. Use 7/16" washers as shims on the 7 ½" bolt, to square the winch plate with the upright, if needed.

NOTE Make sure the plate is bolted to the winch upright before operating the winch.

STEP 3

Bolt the motor (1) to the worm gear assembly (2) using (4) 5/16" x 1 ½" hex bolts, (2) 5/16" wing nuts, (2) 5/16" nuts and (2) 3/8" galvanized fender washers and (2) 5/16" flat washers. Run 5/16" bolts through motor bracket, through worm gear plate, through slots in slide plate (10) and out the back cover. **Only the lower (2) 5/16" bolts go through the slide plate, these are also the bolts that receive wing nuts.* Attach stems (9) in front of back cover behind worm gear, using (2) ½" x 1" machine bolt, (2) ½" washer & (2) ½" jam nuts.

NOTE

Do **not** completely tighten down the motor at this time. Leave the motor loose so you can get the belt on the pulleys.

STEP 4

Put the large pulley on the worm drive unit drive shaft and the small pulley on the motor drive shaft. Do not pound or tap pulley onto shaft as damage to the pulley may occur. Work worm gear shaft with emery cloth until pulley slides onto shaft. Before tightening the pulleys in place with the set screws, make sure the large pulley is directly above the small pulley. Once the pulleys are in line, tighten them in place.

STEP 5

Put the belt over the large and small pulleys. Tighten the belt by adjusting the motor until the belt is snug in place. Then tighten the motor in place.

STEP 6

Attach up/down switch (13) with GFCI (14) coming straight down, with (2) ¼" x 1" machine bolts, (2) ¼" washer & (2) ¼" nuts. **Failure to mount switch will cause switch to retain water & invalidate the warranty.*

STEP 7

Clip the front cover (8) in place by inserting bottom of cover onto stems of the slide plate (10) and lifting top of cover onto top stems (9).

ShoreMaster recommends that an electrician does the installation and hook up of winch.

FOR WARRANTY TO GO INTO EFFECT

An electrician must check the electric motor under a full load to be certain that the proper amount of current is reaching it during all phases of operation.

SHOREMASTER, INC. IS NOT LIABLE FOR ANY INJURY INCLUDING BUT NOT LIMITED TO IMPROPER INSTALLATION, FAULTY WIRING, AND/OR IMPROPER USE.

ELECTRIC POWER UNIT SAFETY

WARNING

1. ALWAYS turn OFF MAIN POWER SUPPLY when moving swimming or working on or around the lift
2. It is recommended that the power be shut off or the motor unplugged when not in use to preserve the life of the motor. This will also prevent unauthorized use of the lift.
3. Proper care should be exercised concerning wires that are exposed to wave or wind oscillations. If wires are exposed, weathered or appear worn turn off the MAIN POWER SUPPLY and have the unit repaired immediately. Kinks or breaks in the wire occur, resulting in SERIOUS INJURY OR DEATH.
4. It is recommended that an electrician do the installation and final inspection of this electric power unit. If at any time the unit is not operating properly, shut down the MAIN POWER SUPPLY and have it inspected by authorized service personnel.
5. NOT COMPLYING WITH THE ABOVE RECOMMENDATIONS MAY INVALIDATE THE WARRANTY OR RESULT IN PERSONNEL INJURY OR DEATH.
6. When operating the electric power unit, make sure the winch driveshaft is turning clockwise when lifting the boat up out of the water and that the ratchet pawl is making a clicking sound. This will allow the winch to brake properly.
7. If you have any questions concerning the installation , operations, or safety of your electric power unit, please call ShoreMaster at 1-800-328-8945

**** GREASE WINCH DRIVESHAFT THREADS AND CHAINS AT LEAST TWICE A YEAR!! PREFERABLY EACH FALL BEFORE STORAGE AND EACH SPRING BEFORE USE****

ELECTRIC POWER UNIT CANTILEVER LIFTS

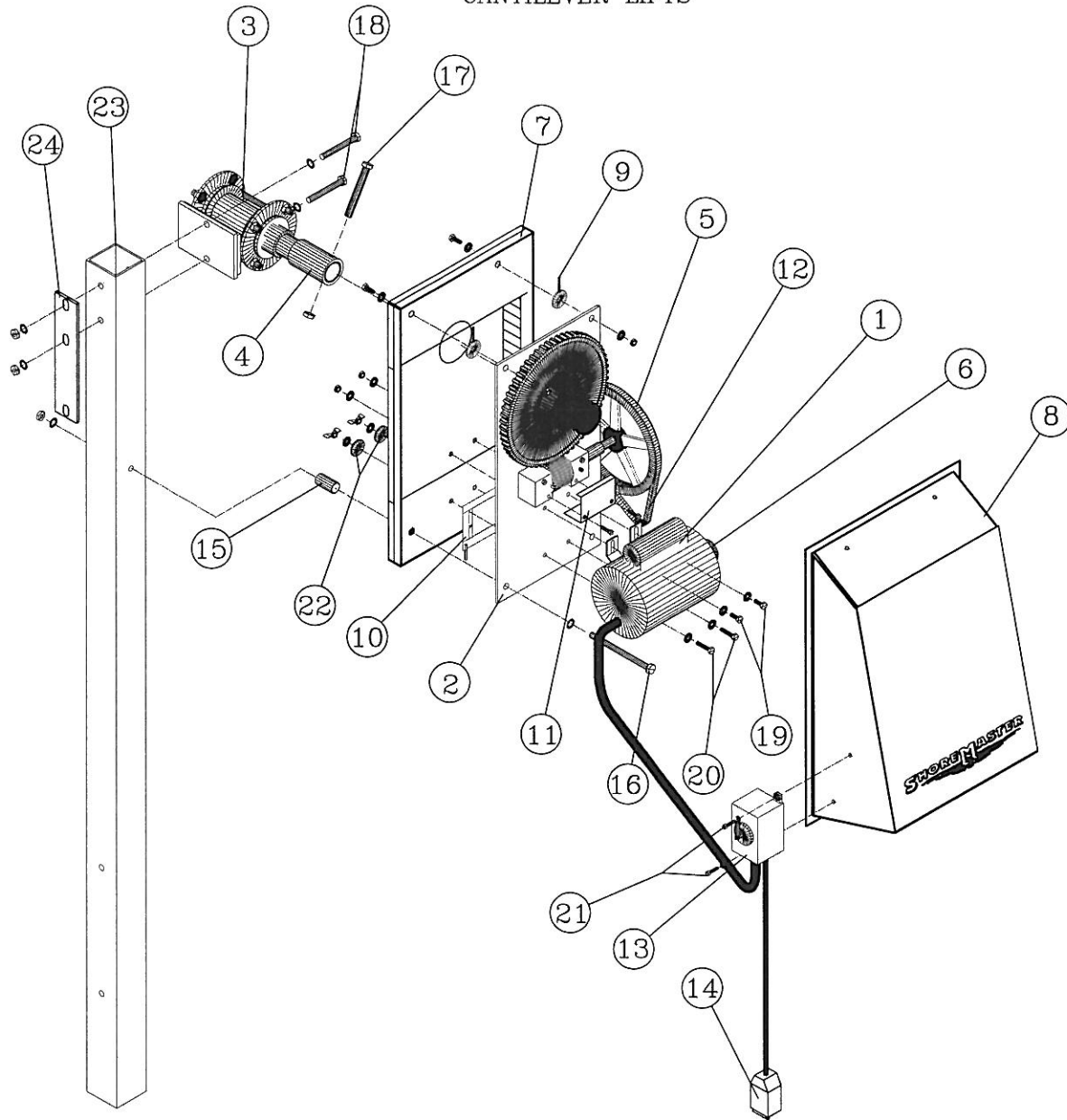

No.	DESCRIPTION
1	MOTOR
2	WORM GEAR ASSEMBLY
3	WINCH HUB
4	SPACER SLEEVE
5	LARGE PULLEY
6	SMALL PULLEY
7	BACK COVER
8	FRONT COVER
9	STEM
10	SLIDE PLATE
11	GREASE CUP
12	BELT
13	UP/DOWN SWITCH
14	GFCI
15	SPACER
16	3/8" x 7-1/2" or 8" MACHINE BOLT, (2) 3/8" WASHERS, (1) 3/8" NUT.
17	(1) 1/2" x 3-1/2" MACHINE BOLT, (1) 1/2" NUT.
18	(1) 1/2" x 4-1/2" MACHINE BOLT, (2) 1/2" WASHERS, (1) 1/2" NUT, (2) PLACES
19	(1) 5/16" x 3/4" MACHINE BOLT, (2) 5/16" WASHERS, (1) 5/16" NUT, (2) PLACES
20	(1) 5/16" x 1-1/2" MACHINE BOLT, (2) 5/16" WASHERS, (1) WING NUT, (2) PLACES
21	(1) 1/4" x 1" MACHINE BOLT, (2) 1/4" S.S. WASHERS, (1) 1/4" S.S. NUT, (2) PLACES
22	GALVANIZED FENDER WASHER
23	LIFT SIDE
24	WINCH PLATE

INSTALLATION

The following are guidelines or suggestions for installation. Situations vary between installation sites. Common sense may dictate that other factors be considered in your situation. Your site may not allow for some of our suggestions to be used or followed entirely. Do not, under any circumstances, endanger yourself or risk damage to lift or boat when installing.

CAUTION

If you are unable to properly and safely install this boat lift, **please have a trained boat lift installer perform the installation.**

#1 Measure water depth of exact position you want to locate lift.

#2 Before installing, adjust lift legs so lift can be properly positioned in water.

Note: Lift must be positioned low enough so boat can float into position before raising, while also allowing high enough position so the boat can be fully raised up and out of water.

Note: Lift rack must always be in partially raised position (6" above rear bottom beam) before any weight is applied. Lift rack must never rest on rear bottom beam during use. Adjust lift legs down or move lift to deeper water if this is a problem!!!

CAUTION

Never apply weight on lift when top rack is in fully lowered position. Doing this will bend lift frame and cause permanent damage to lift.

#3 Be sure security ropes are still in place. This will prevent rack from pivoting when moving lift into position.

Note: Remove ropes when lift is in place.

CAUTION

A freely pivoting lift rack could cause a pinching or cutting injury during installation. Be sure lift rack is properly secured when installing. Never move or lift your boat lift by grabbing the lift rack or I-beams.

#4 Carry, lift, roll, float or slide lift into position. Position alongside dock so hand wheel can be easily turned from dock.

CAUTION

Lift must be resting on lake bottom in a level, secure and stable position for safe operation. An unstable lift installation could result in tipping of lift during operation, causing damage to watercraft, and crushing or pinching injury to operator.

OPERATION

-Loading of Watercraft-

CAUTION

Remove safety ropes before using lift. Be sure when removing that cable is wrapped tight. Winch up excess cable to avoid rack dropping when undoing ropes.

#1 Be sure lift rack and cradles or bunks are positioned below water surface so they will not interfere with boat floating into position.

CAUTION

Be sure boat is properly balanced and centered on lift before raising.

CAUTION

If lift is without a boat in it for more than one day, raise the rack (pulleys and cable) fully out of the water to help prevent corrosion of these parts.

#2 Position boat with center of gravity near middle of lift. For most rear engine mounted boats, this requires you to position the boat mostly forward in the lift.

WARRANTY DOES NOT
APPLY IF DAMAGE IS
CAUSED BY IMPROPER
LOADING!!

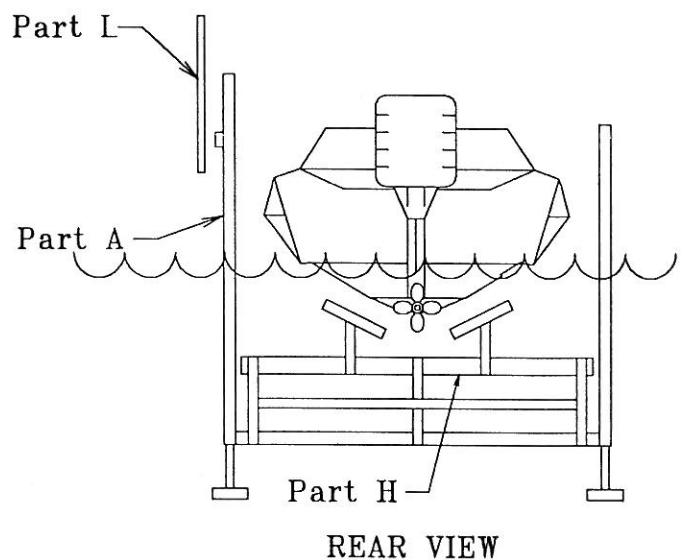

-Raising Lift-

#1 Make sure boat is in proper position. Turn winch driveshaft clockwise (in direction of up arrow). Stop turning when craft reaches desired height out of the water.

WARNING

Stay clear of lift (facing wheel) while operating. Do not allow anyone on, in or under lift. A cable or lift part failure can cause a sudden drop of boat, resulting in a crushing or falling injury or death!

CAUTION

Turn wheel in direction of arrow (clockwise) to raise lift. A clicking sound is heard when properly raising lift. Turning wheel and wrapping cable in wrong direction will cause fast spin down of wheel.

CAUTION

If fast spin down of wheel occurs do not touch wheel or attempt to stop. Placing hands or feet on spinning wheel can cause broken or cut limbs.

CAUTION

Properly cover your boat, when in raised position, if rain can gather in your craft. An inch of rain adds several pounds to lift. Added weight may result in boat being over capacity.

CAUTION

Do not over raise lift rack. If wheel is over rotated and rack is over raised it could cause damage to lift and may leave you unable to lower lift back down.

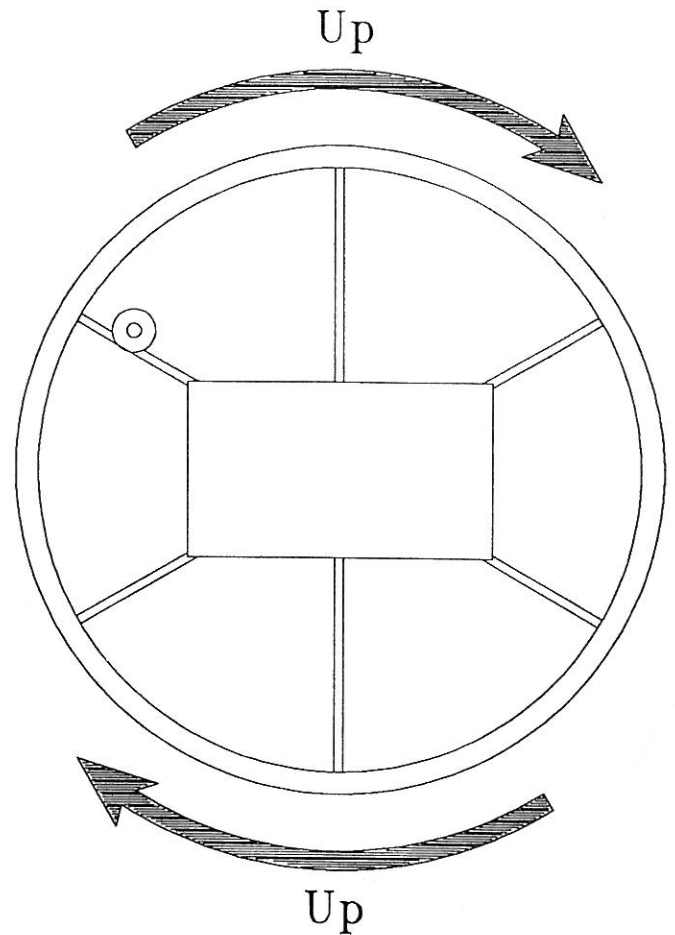

#2 Optional: Lock and chain wheel for security.
You may also lock and chain rack to both front lift uprights to secure boat from cable or winch failure.

CAUTION
Do not allow people on boat when in a raised position on lift. Entering boat when in the raised position adds to lift load and is not safe! A falling injury could occur should lift fail.

CAUTION
Do not allow anyone who is in the water within six feet of the lift. A crushing injury could occur to swimmer should cable, winch brake or lift part fail.

-Lowering Lift-

#1 Turn winch driveshaft counterclockwise (in direction of down arrow).

Note: Turn wheel down one or two turns past point when craft begins to float (This must always be at some point before lift rack is contacting rear bottom beam). Then turn wheel up slightly until clicking sound is heard to secure wheel position and brake on winch.

CAUTION
Winch Safety - Never disconnect ratchet pawl, gear or brake mechanism to lower lift wheel. Disconnected or faulty brake parts will result in rapid spinning of wheel.

CAUTION
Do not over lower wheel so slack develops in cable. Doing this could cause cable to jump off winch spool. This may result in sloppy wrapping of cable next time you raise the lift, resulting in premature wear or cable breaking.

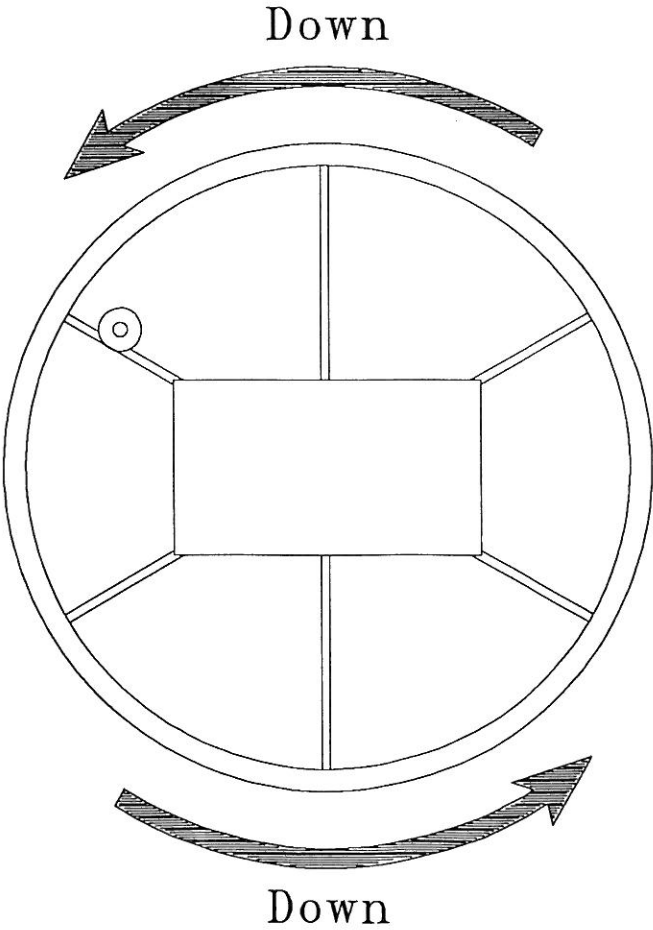

REMOVAL & STORAGE (winterizing)

****ShoreMaster does not warrant this product against any damage caused by or related to ice!!**

CAUTION

Ice can severely damage your boat lift. Do not leave lift, or boat on lift, in water if ice damage is possible.

#1 Tie lift rack securely to lift side uprights in opposite corners. This will prevent rack from pivoting when moving lift out of water.

Note: Remove ropes when lift is reinstalled.

CAUTION

A freely pivoting lift rack could cause a pinching or cutting injury during removal. Be sure lift rack is properly secured when removing. Never move or lift your boat lift by grabbing the lift rack or I-beams.

#2 Carry, lift, roll, float or slide lift out of water. Position safely away from potential ice build up.

SERVICE (Maintenance)

#1 Inspect nuts and bolts at least every six months for damage, wear or loose connections. Tighten or replace parts as needed.

CAUTION

Check cables for frays, corrosion or breaks at least once a month. A cable breaking while boat is in lift could damage boat or lift. Severe bodily injury could also occur.

#2 Inspect lift frame, pulleys, winch and pivot points at least every six months for unusual wear, damage or bent parts. Replace or repair as needed.

#3 Lubricate winch and wheel threads at least every six months.

Note: Do not get lubricant on brake pads! Brake will fail and wheel will spin down if brake pads are lubricated.

#4 Lubricate pulleys at least every six months. Check pulley nuts and bolts during assembly and every six months to make sure they are properly tightened.

#5 ShoreMaster dealers usually offer service visits. Please contact them if you are unable or unwilling to perform maintenance or service to lift.